



Hard- und Software Burkhard Lewetz

Technical Software Engineering

Documentation ***3D-Probe / Z-Probe***

This document contains an overview of the technical details, a description of the scope of delivery and instructions for connecting and configuring the 3D-Probe and the Z-Probe tool length and Z zero point probe.





Table of contents

Functional description.....	2
Technical details	3
Pin assignment	6
Pin assignment with <i>ncUSB</i> module withput external power supply.....	6
Pin assignment with external power supply	8
Testing the function with the signal test	9
Further informations / Questions	10



Functional description

The sensor **3D-Probe** is suitable for use as a 3D probe with **WinPC-NC** or other control software. With the **3D-Probe**, non-planar surfaces can be measured automatically and three-dimensional bodies can be scanned precisely.

Further applications are the precise determination of the center of a hole or the probing of the zero point or edges of a workpiece.

The probe tip is replaceable and can be reordered individually if required. The probe housing is dust-protected and the probe tip can be mechanically calibrated via three screws.

The **Z-Probe** surface probe can be used both as a flying probe for determining the Z zero point and as a permanently installed probe for determining and correcting tool lengths.

3D-Probe and **Z-Probe** were developed for high measuring precision and high repeatability at a good price-performance ratio and optimized for use with **WinPC-NC**.

Both probes are equipped with measuring electronics for more accurate evaluation, the **3D-Probe** is additionally equipped with an LED to indicate the current switching state.

The probes are delivered with a special cable with magnetic contacts. This allows both probes to be connected consecutively to the same cable and eliminates the need for external electronics. In addition, the contacts are always in contact due to the magnetic holder and the probes can be replaced without additional tools.

Both probes are optimized for use with **WinPC-NC**. The probes can be connected directly to the **ncUSB** module of **WinPC-NC USB** or other hardware without any further components by using the supplied screw terminal. For use with other control software, an external power supply is recommended.

You will find further information on connection and parameterization below. Further information about the Auto-Levelling function with the **3D-Probe** can be found on our website under the tab **FAQ - How to with WinPC-NC ?**



Technical details

3D-Probe and Z-Probe

Power supply voltage	5-24V DC
Current consumption	<35mA
Output type	NPN
Switch type	Normally closed / NC
Max. output voltage	24V DC
Max. output current	50mA
Cable length	2m
Repeatability 3D-Probe	< 0,03mm
Repeatability Z-Probe	< 0,007mm

Wire colour assignment

Brown Power supply (5V-24V DC)

Blue GND power supply

Black Switching output



Mechanical dimension 3D-Probe

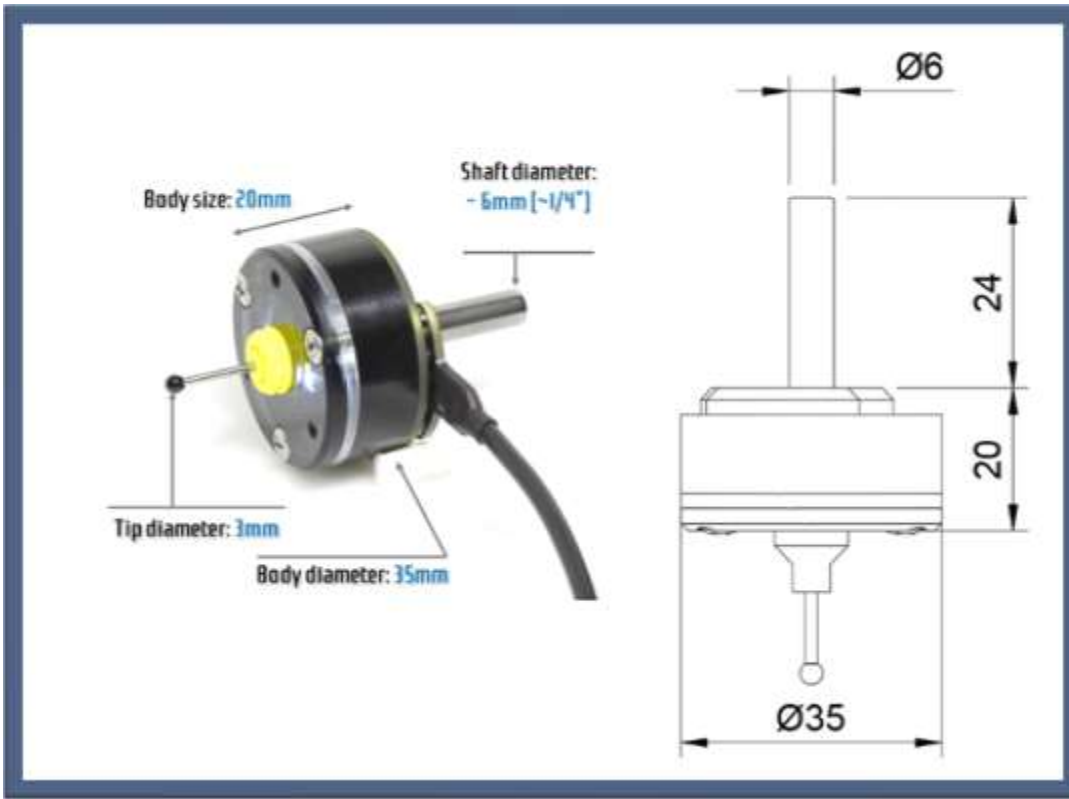

Mechanical dimension Z-Probe

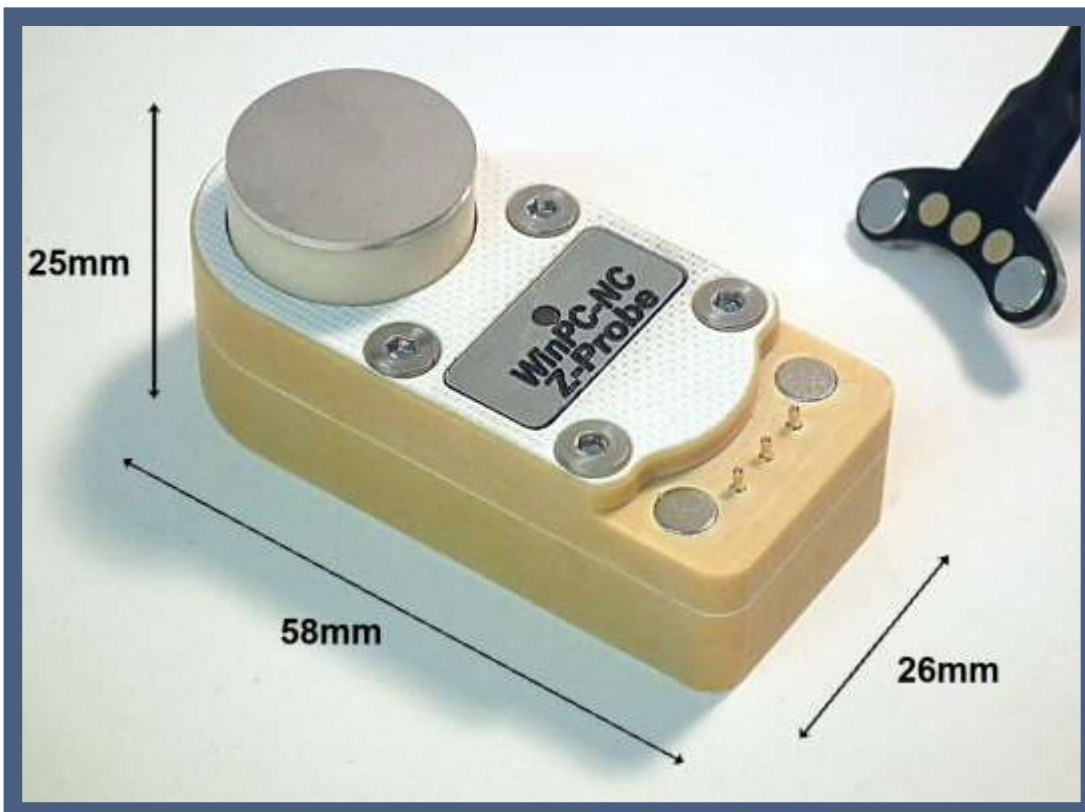



Scope of delivery

Both probes are available individually as well as in a set. We also offer other accessories and spare parts in our store.

3D-Probe

The **3D-Probe** is delivered with the following scope of delivery

- **3D-Probe**
- Holder for **3D-Probe**
- Spare cover for touch tip made of plastic
- Connection cable 2m with magnetic connector
- 25 pole screw terminal for easy connection to control hardware

Z-Probe

The tool length and Z zero point probe is delivered with the following scope of delivery

- **Z-Probe** sensor
- Connection cable 2m with magnetic connector
- 25 pole screw terminal for easy connection to control hardware

3D Probe, Z-Probe Set

The **3D-Probe** and **Z-Probe** set is delivered with the following scope of delivery

- **3D-Probe**
- **Z-Probe** sensor
- Connection cable 2m with magnetic connector
- Holder for **3D-Probe** and **Z-Probe**
- Spare cover for touch tip made of plastic
- 25 pole screw terminal for easy connection to control hardware



Pin assignment

The **3D-Probe** and **Z-Probe** can be connected directly to the **ncUSB** module of **WinPC-NC USB** without any additional components. Furthermore, both probes can be used with the optionally available power supply unit or an existing power supply between 5V-24V DC also directly with our control unit **CNCCON S** at connector X4.

Pin assignment with **ncUSB** module without external power supply

In the easiest way, the probe is connected to the LPT2 interface of the **ncUSB** module. The connection is made as follows:

Wire colour	Pin LPT 2 ncUSB
Brown	LPT2 Pin 1
Blue	LPT2 Pin 18
Black	LPT2 Pin 10

In the Signal Wizard in the basic settings, the probe at pin 10 of the LPT2 port must be assigned so that **WinPC-NC** can recognize it.

For this in the parameters under Basic settings-Signal Wizard the input **I221 surface sensor** is assigned to pin LPT2 pin 10.

That the supply voltage for the probe is output at the **ncUSB** module on the LPT2, the output pin **Q255 Ready** must be assigned to pin LPT2 pin 1.

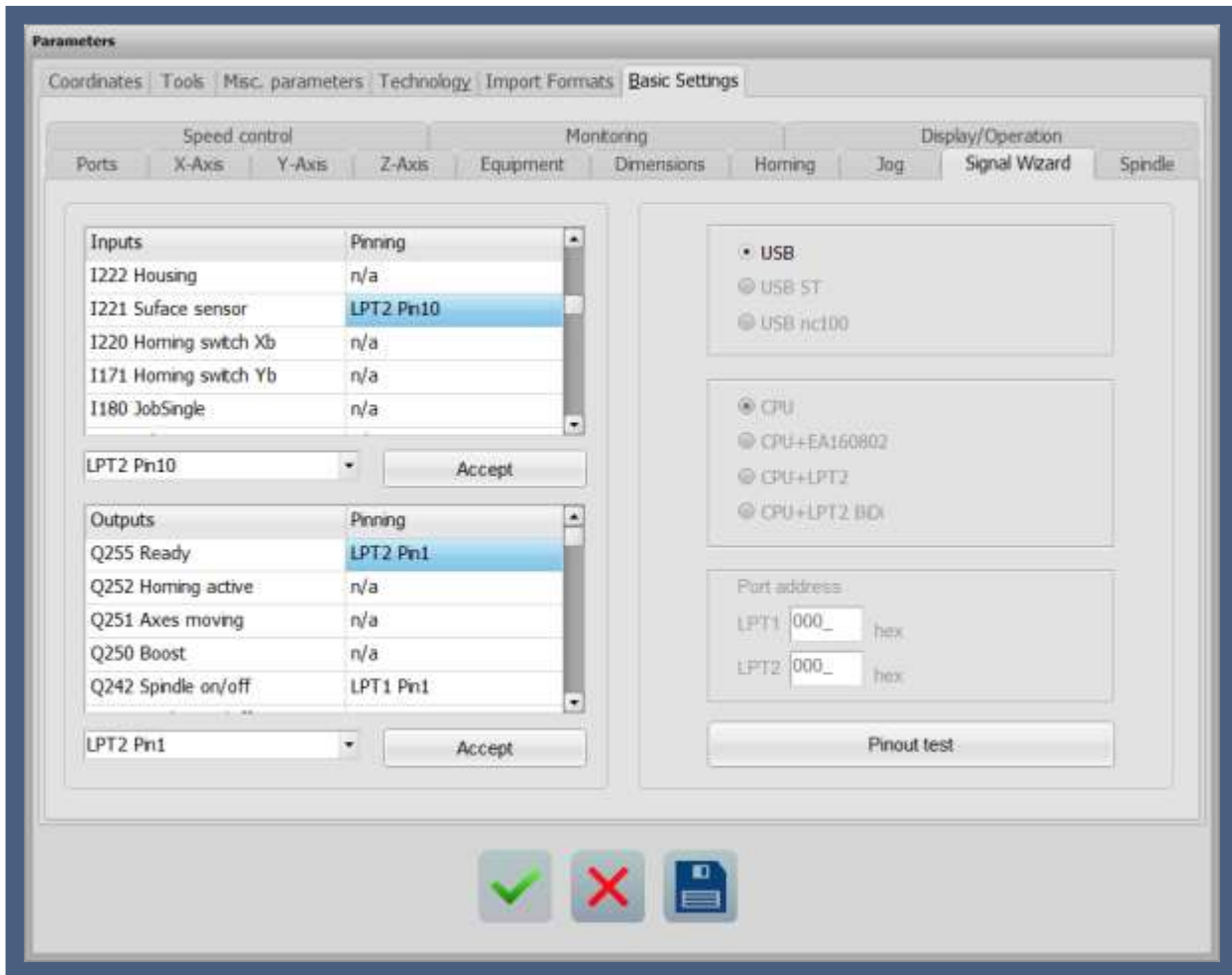

Signal Wizard in **WinPC-NC** with assigned input **I221 Surface sensor** and Output **Q255 Ready**



Pin assignment with external power supply

The probes can be connected to our **CNCCON S** axis controller or control hardware of other manufacturers as listed below. The external power supply requires an output voltage of 5V-24V DC.

Wire Colour	Pin LPT Port	Pin Power supply
Brown	-	+5V-24V DC
Blue	GND For WinPC-NC Pin 18-25	GND
Black	Input pin of control hardware For WinPC-NC Pin 10, 11, 12, 13 or 15	

In order for **WinPC-NC** to recognize the probe at the selected pin, this must be assigned in the Signal Wizard in the basic settings.

For this the input **I221 Surface sensor** is assigned to the input pin with connected probe in the parameters under Basic settings-Signal Wizard.



Testing the function with the signal test

After the probe has been connected correctly and configured in **WinPC-NC**, you can check its functionality with the signal test. For this purpose, the signal test is opened in the **WinPC-NC** main menu under Special functions-Signal test.

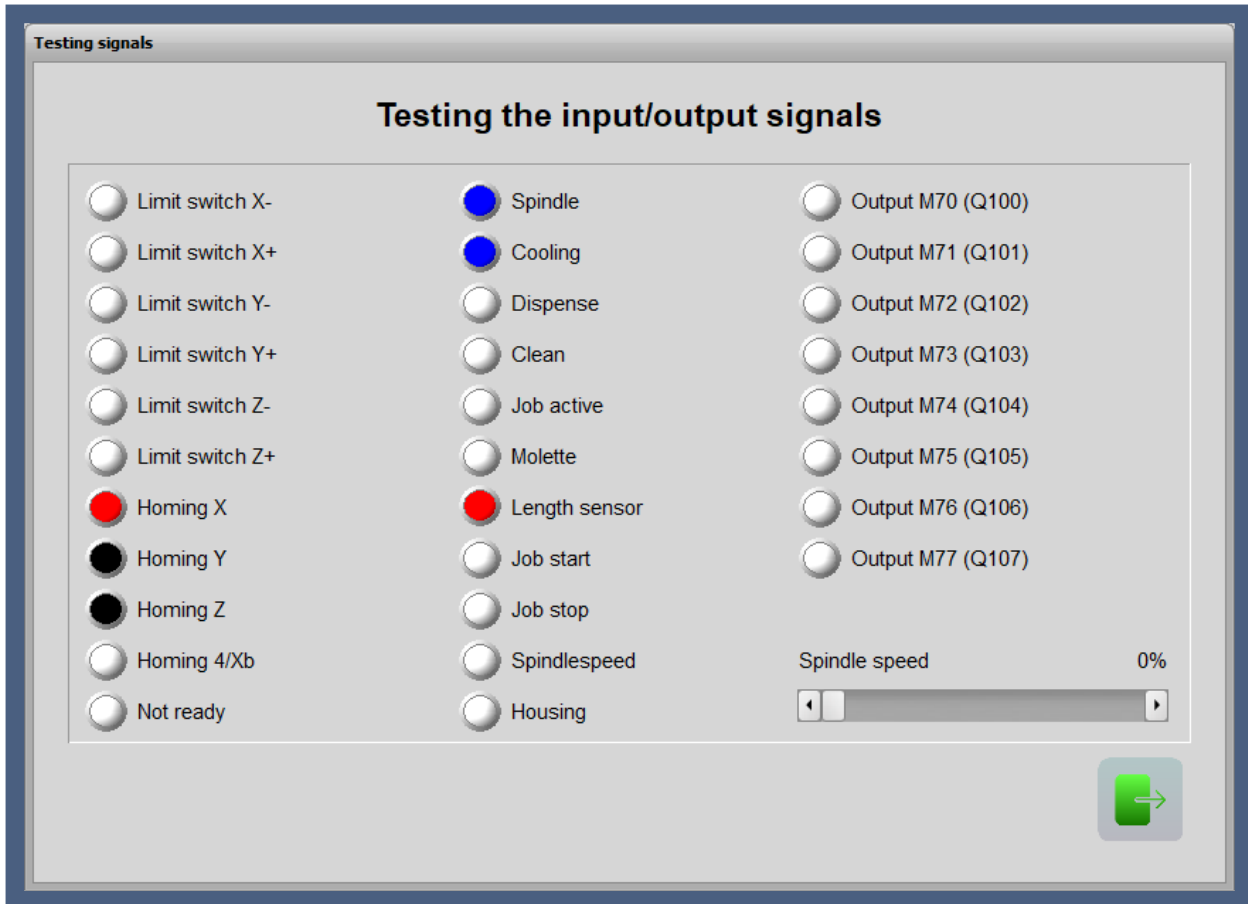

Signal test with activated probe

If the probe is operated manually, the display signal must turn red when the probe is pressed. In the unactuated state, the display signal is black.



Further informations / Questions

You can find more information about the use of the buttons and the configuration in further short instructions on our homepage under the tab **FAQ-How To with *WinPC-NC***.

Among others, you will find the following information there:

- Scanning and autolevel with ***WinPC-NC*** and ***3D-Probe*** for non-planar surfaces
- Z-zero probe and material thickness
- Z-zero adjustment, by hand or with probe and determination of the probe block dimension
- Tool changer start-up
- For further information on tool length measurement and compensation please refer to the manual of ***WinPC-NC***